

Surge Protective Devices

**TranTrack 2 Series:
065 and 100**

Installation,
Operation and
Maintenance
Manual



TABLE OF CONTENTS

Before Installation	3
<i>System Configuration Verification</i>	3
<i>Environmental Condition Verification</i>	4
<i>Wiring Connection Diagrams</i>	4
<i>Upstream Over-Current Protection Device</i>	4
<i>Conductor Routing</i>	4
<i>Mounting</i>	5
<i>Optional Flush Mounting</i>	6
<i>Electrical Connections</i>	7
<i>Verification and Power Up</i>	7
Troubleshooting	8
Warranty Statement	8

BEFORE INSTALLATION



WARNING: HAZARDOUS VOLTAGES PRESENT Improper installation or misapplication may result in serious personnel injury and/or damage to electrical system. Read the complete installation instructions before proceeding with installation. Remove all power to the electrical panel before installing or servicing the surge protective device (SPD).

IMPORTANT SAFETY INSTRUCTIONS All work must be performed by licensed and qualified personnel. The electrical system must be properly grounded in accordance with the U.S. National Electrical Code, state and local codes or other applicable codes for this SPD to function properly. Do not connect TransTrack2 to the line side of the main service breaker or disconnecting means. This device is suitable for installation where the available short circuit current is 200,000 rms symmetrical amperes at 600VAC or less.



WARNING: Check to ensure that a proper bond is installed between neutral and ground at the transformer upstream from the split-phase TransTrack2 device (See NEC Article 250). If the transformer is not accessible, check the main service disconnect/panel for the N-G bond. Lack of a proper bond will damage TransTrack2 and void the warranty.

1. System Configuration Verification

Confirm that the voltage and service configuration shown on the TransTrack2 product label is consistent with the voltage and service configuration of the facility. A model number is located on a label on the outside of unit.

MODEL NUMBER	NOMINAL VOLTAGE	L-N VOLTAGE RANGE	L-L VOLTAGE RANGE	CONFIGURATION
TK-TT2-xxx-1P240	240	N/A	216-264	Single Phase, 2-wire+ground
TK-TT2-xxx-1S240	120/240	108-132	216-264	Split-Phase, 3-wire+ground
TK-TT2-xxx-3Y208	120/208	108-132	187-228	Three-Phase, 4-wire+ground
TK-TT2-xxx-3Y380	220/380	198-242	342-418	Three-Phase, 4-wire+ground
TK-TT2-xxx-3Y480	277/480	249-305	432-526	Three-Phase, 4-wire+ground

65kA or 100kA surge rating per phase

2. Environmental Condition Verification

Confirm that the environmental conditions are consistent with the following ranges:

- Ambient Temperatures: Between -40° and +158°F.
- Relative Humidity: Between 5% and 95% non-condensing.
- Altitude: Less than 13,000 feet.

3. Wiring Connection Diagrams

Figure 1 shows the electrical relationship between TransTrack2 and the service configuration: Single Phase, 2-wire; Split-Phase, 3-wire, and Three Phase, 4-wire WYE.

Fig. 1: Single Phase, 2-Wire

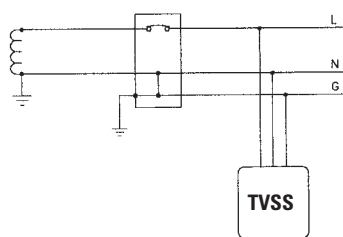

Fig. 2: Split Phase, 3-Wire

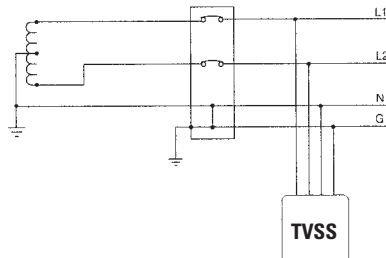
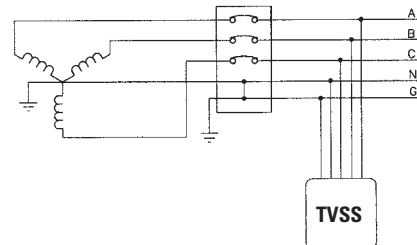

Fig. 3: Three Phase, 4-Wire WYE



Connections to the SPD are clearly identified and are made via pigtail leads supplied with the unit. For split phase units, the phase connections are marked “A/L1” and “C/L2”. The neutral (when applicable) is a white wire and the ground is a green wire.

4. Upstream Over-Current Protection Device

TransTrack2 must be connected in parallel to the electrical system.

TransTrack2 units have built-in over-current fusing rated at 200,000 rms symmetrical ampere at 600VAC or less and can be connected directly to the electrical distribution system bus without an upstream over-current protection device. However, the use of an external over current protection device is recommended.

If the TransTrack2 is connected to a dedicated overcurrent protection device, a 30A breaker is recommended (15A minimum, 200A maximum). The advantage of using a dedicated over-current device for the TransTrack2 (even if the upstream breaker is 200A or less) is that it allows the TransTrack2 to be de-energized during service without disturbing the electrical service to the rest of the facility.

5. Conductor Routing



TransTrack2's performance will be limited severely if the conductors are (a) too long, (b) have too many bends or (c) have sharp bends.

The factors listed above should be addressed during the design of an installation to reserve a suitable place for TransTrack2 next to its point of connection to the electrical system. The selected mounting location should allow for the shortest possible conductor runs and a direct route with a minimum of bends. If bends are required, they should be *sweeping* bends (12" radius). Do not make sharp 90° bends for appearance purposes because they will severely decrease the effectiveness of TransTrack 2.

Binding or twisting conductors together using tie-wraps or electrical tape increases the protection performance of the device.

6. Mounting

TransTrack2 can be mounted in a variety of methods. The basic method is to wall mount using the mounting feet attached to the base of the enclosure. TransTrack2 can also be mounted even (or flush-mount) to the exterior wall surface. Mount TransTrack2 using construction methods and hardware appropriate for your site. The TransTrack2 enclosure is designed with a 3/4-inch myers hub which will accept rigid or IMC conduit. See Figure 2 for enclosure and mounting dimensions.

Fig. 2
Enclosure/Mounting
Dimensions

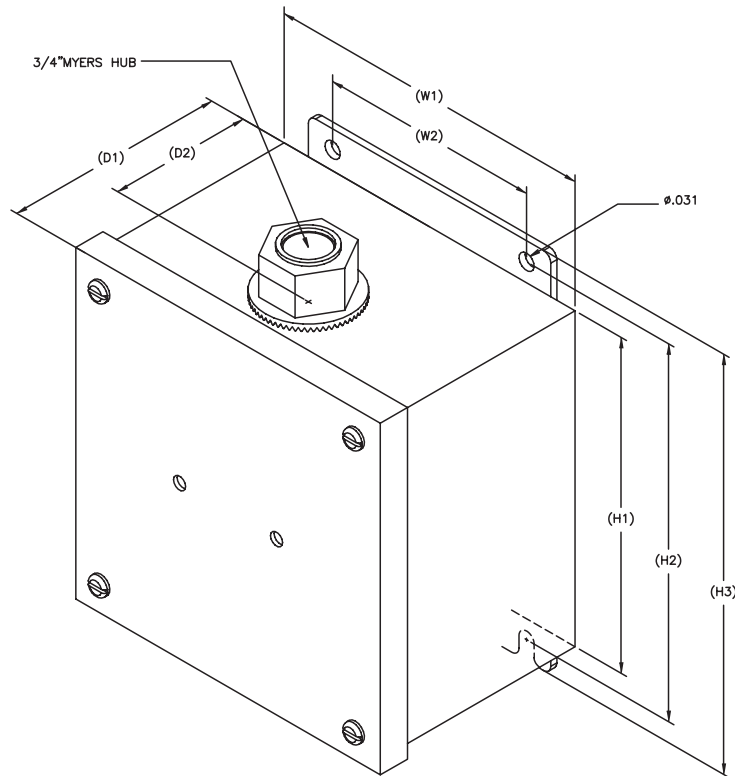

Without Flush Plate

DIM	IN	(mm)
H1	6.00	(152.4)
H2	6.75	(171.5)
H3	7.50	(190.5)
W1	6.00	(152.4)
W2	4.00	(101.6)
D1	4.16	(105.7)
D2	2.50	(63.5)

All measurements in inches (mm)

7. Optional Flush-Mount Plate

Optional flush-mount plate, part number FMP, can be purchased for flush-mount installation. Typically a cutout, larger than the TransTrack2 enclosure, is created in the drywall or other finish material. See Figure 3 for the recommended cutout gap (dimensions L1 and L2). Use the flush-mount plate to hide the gap between the enclosure and the cutout edges. Prior to installation, attach the plate to the enclosure using the existing cover screws.

**Fig. 3:
Flush-Mount Plate
Dimensions**

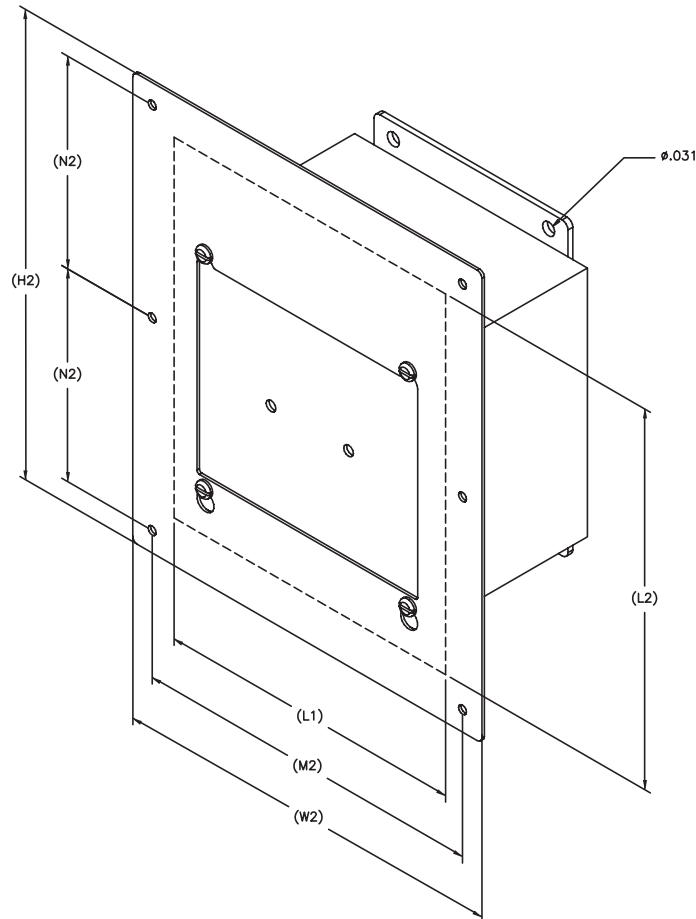

With Flush Plate

DIM	IN	(mm)
H2	10.50	(266.7)
L1	7.00	(177.8)
L2	8.50	(215.9)
M2	8.00	(203.2)
N2	4.75	(120.6)
W2	9.00	(228.6)

All measurements in inches (mm)

8. Electrical Connections



CAUTION: Prior to installation ensure the system configuration and voltage is equivalent to the TransTrack2 unit being installed.

Following all applicable National Electrical Code standards as well as state and local codes, connect phase, neutral* and ground to TransTrack2. Ensure that the conductor lengths are kept as short and straight as possible.

9. Verification and Power Up

Apply power to TransTrack2 by closing the over-current protection device or switch feeding the suppressor.

Fig. 4
TransTrack2 Diagnostics

Verify that all “Phase Protection Status” indicating lights are illuminated.



TROUBLESHOOTING

Your TransTrack2 system does not require scheduled maintenance. The unit's heavy-duty construction is designed to provide years of uninterrupted service. The unit contains no serviceable parts.

INDICATION	PROCEDURE
One or more phase protection status indicating lights are off, check system indicating light is on.	Verify that the input power feeding TransTrack2 is energized using a voltage tester. If power is present, contact factory for assistance: www.tpsjoslyn.com

INFORMATION	EXAMPLE
Model Number	TK-TT2-065-1S240-FL
Serial Number	16230-0104-002
Date of Purchase	January 2, 2006
Sales Order Number	16230
Description of Failure	"Check System" indicating light illuminated
Desired Action from Joslyn	Replace

WARRANTY STATEMENT

During the applicable warranty period, any Total Protection Solutions™ surge protector device which fails due to defect in materials, workmanship, or any electrical anomaly, including lightning, shall be repaired or replaced at Joslyn's discretion.

Prior to shipment of any suspect or known defective product to Joslyn a Return Material Authorization (RMA) number must be obtained. An official Joslyn RMA number and shipping instructions can be obtained from the distributor where the product was originally purchased. Distributors can obtain the official Joslyn RMA number by contacting the Joslyn Customer Service Department at 800-647-1911. Products arriving at Joslyn without an official RMA number will not be accepted and will be returned freight collect to the original point of shipment.

Products being returned with an official Joslyn RMA number should be shipped by prepaid freight to the nominated point of return as shown on the RMA documentation.

The Company shall have no liability under this warranty for problems or defects directly or indirectly caused by misuse of the Product, alteration of the Product (including removal of any warning labels), accidents, improper installation, application, operation or improper repair of the Product.

THIS WARRANTY REPRESENTS THE ENTIRE WARRANTY OF THE COMPANY. ALL OTHER WARRANTIES EXPRESS OR IMPLIED, ORAL OR WRITTEN, INCLUDING, BUT NOT LIMITED TO, THE WARRANTIES OF MERCHANTABILITY AND FITNESS FOR A PARTICULAR PURPOSE ARE HEREBY DISCLAIMED.

THE LIABILITY OF THE COMPANY, AT ITS SOLE OPTION, UNDER THIS WARRANTY IS EXPRESSLY LIMITED TO THE REPLACEMENT OR REPAIR OF THE DEFECTIVE PART THEREOF. IN NO EVENT SHALL THE COMPANY BE LIABLE OR RESPONSIBLE FOR SPECIAL, INCIDENTAL, OR CONSEQUENTIAL DAMAGES OF ANY KIND OR CHARACTER, NOR SHALL ITS LIABILITY EVER EXCEED THE PURCHASE PRICE PAID TO JOSLYN FOR SUCH DEFECTIVE PRODUCT.

This warranty is not transferable and may only be enforced by the original purchaser. Claims under this warranty must be submitted to Joslyn within thirty (30) days of discovery of any suspected product defect.



Warranty Period

TransTrack2 25 Years from original date of purchase



5900 Eastport Boulevard Richmond, VA 23231-4453 USA
TEL: 800.647.1911
www.tpsjoslyn.com